

1. PRECAUTION

Please read through this Manual before use of the instrument for correct handling. Please keep this Manual carefully after use. This instrument has been thoroughly tested at the factory before shipment. When you receive it, visually inspect it for damage and check the accessories.

- ① Model number and specifications check
Check to see model number and specifications on the plate attached to side face of the transmitter are as ordered.
- ② Contents of the instruction manual
This instruction manual provides instructions on handling, external wiring and safety use of the transmitter.

2. GENERAL

This compact plug-in type CT Transmitter converts AC current signal (CT output, etc.) into isolated DC voltage or DC current signal.

Accessories :

- Tag Number Label 1
- CT protector (in case specify optional)... 1

3. MOUNTING METHOD

JUXTA VJ Series Transmitters can be mounted on wall, DIN rail or multi-mounting base.

NOTE: Direction of insertion/extraction
Insertion/extraction of main body into and from socket should be done in vertical direction against face of socket. Slanting insertion or extraction makes terminals bent causing bad contact with socket.

3.1 Wall Mounting

Loosen the socket's fixing screw as shown in Fig. 1 and pull out the main body from socket. Then fix the socket on the wall with screws. See Fig. 3 for mounting method.

3.2 DIN rail mounting

Insert DIN rail into the upper of the DIN rail groove on rear of socket of the transmitter and fix the rail with slidelock at the lower of the transmitter as shown in Fig.2.

3.3 Multi-base mounting

As for multi-base mounting, refer to Instruction Manual for VJCE (VJ mounting base).

3.4 Duct Installation

Install ducts, if necessary, aperting from top or bottom face of the transmitter more than 30mm.

4. EXTERNAL WIRING

CAUTION Wiring should be done after ensuring power break of cable.

See Fig.4 for terminal arrangement and Fig.5 for wiring.

Wiring should be done to M3 screw terminals of the socket.

Use round crimp-on terminals for connection to terminals.

- Signal cable having more than 0.5mm² and power cable having more than 1.25mm² of nominal cross-sectional area of conductor are recommended to be used.

FIG.1 WALL MOUNTING

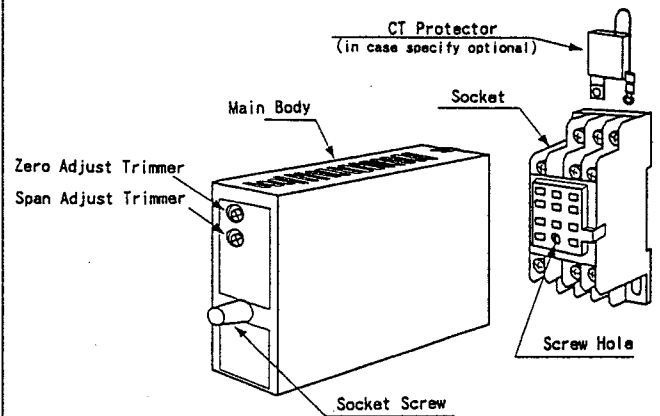

FIG.2 DIN RAIL MOUNTING

When remove the transmitter from DIN Rail, lower the slidelock with (-) screwdriver

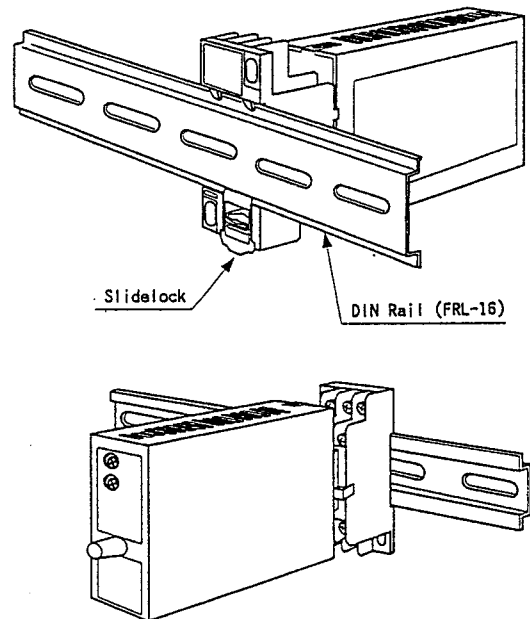
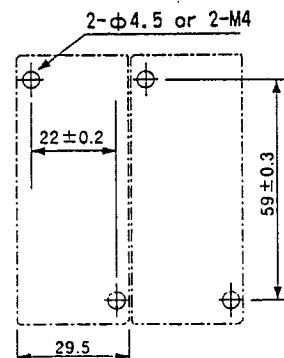

FIG.3 MOUNTING DIMENSION

Unit : mm



4.1 Wiring

- ① Connect input signal cable to 1(A), 3(±), of transmitter.
 - ② Connect output signal cable to 7(+), 9(-).
 - ③ Connect power cable to 8(GND), 10(L+), 11(-N).
- NOTE : Apart wiring of power cable and input/output cable from noise source. Otherwise, accuracy may not be warranted.

5. INSTALLATION AND HANDLING

- ① Avoid installation in such environments as shock, vibration, corrosive gas, dust, water, oil, solvent, direct sunlight, radiation, powerful electric and magnetic fields.
- ② In order to protect transmitter from inducement of thunder surges in power and signal cables, use arrester between the transmitter and equipment installed in the field.

6. SAFETY USE

Following caution for safety should be taken for handling of transmitter. We are not responsible for damage caused by use contrary to caution.

CAUTION

- When install the main body, fix it to the socket with screws after inserting it into socket.
- Following items should be checked before power on. Use of the transmitter by ignoring the specifications may cause overheating and burning.
 - (a) Voltage of power supply and input signal be applied to the transmitter should meet with required specifications.
 - (b) External wiring to terminals should be connected correctly (See Article 4).
- Do not use the transmitter in such dangerous places where exist inflammable and explosive gas or steam.
- Carry out to pull out transmitter from socket after breaking current of CT primary side. If CT protector is connected to current input terminal of CT secondary side, transmitter can be pulled out without breaking-current. However, don't leave it at this status for more than 1 minute. Pulling out transmitter from socket without setting CTG-5 is dangerous for high voltage on secondary side of CT. CT may sometimes be burned.

7. MAINTENANCE

Carry out the following calibration after warmup the transmitter for more than 10~15 minutes to satisfy its specified performance.

7.1 Calibration equipment

- Voltage/Current Generator 1
(Yokogawa Type 7651 or equivalent)
- Voltmeter 1
(Yokogawa Type 7562 or equivalent)
- Precision Resistor 250Ω±0.01% 1W 1

7.2 Calibration

- ① Connect each equipment as shown in Fig.6
- ② Input/output characteristic check
Use Voltage/Current Generator and apply input signals corresponding 0%, 25%, 50%, 75%, 100% of input span to the transmitter. Check to see corresponding output voltages are 0%, 25%, 50%, 75%, 100% respectively and are within specified accuracy rating. R is used for current output.
- If output signal is out of accuracy rating range, adjust it using span and zero adjust trimmer on front face of the transmitter. (See Fig.1)

FIG.4 TERMINAL ARRANGEMENT & TERMINAL CONNECTION

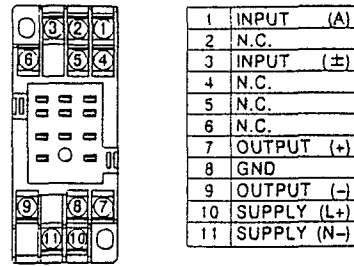

FIG.5 WIRING

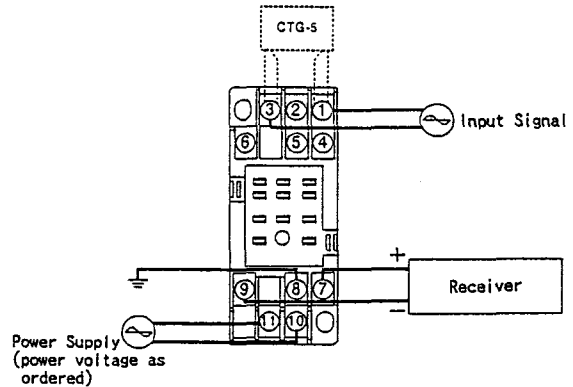
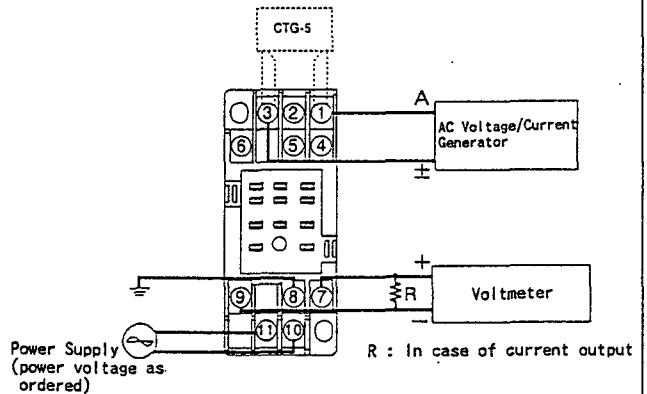

FIG.6 WIRING OF CALIBRATION EQUIPMENT



Subject to change without notice for grade up quality and performance.